



Offset and Position Detection Tools

COMPACT SENSOR SERIES

BIG DAISHOWA SEIKI CO LTD

CATALOG No. **EXi 68**

**High precision Compact Sensor Series
enhances accurate machining.**

Measuring Device

BASE MASTER
BASE MASTER MICRO
POINT MASTER

BASE MASTER GOLD
TOOL MASTER
ACCU CENTER





Tool Offset Sensors

BASE MASTER Series

Precision tool to define work offsets and tool lengths.

- LED lamp illuminates at exactly 2.000" from the reference surface.
- Repeatability of $\pm .00004"$.
- Safety over-travel of sensor plate prevents damage to tooling.
- Magnetic base mounts vertically, horizontally, or at any angle.

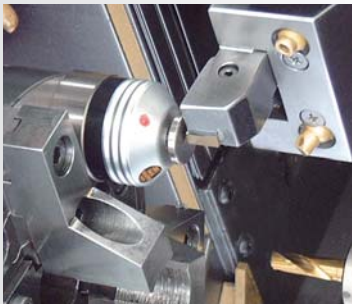

BASE MASTER

For cutting tools, workpieces and machine tools using conductive materials.

Model **BM-2**



Integrated contact switch

BASE MASTER GOLD

For all materials, including non-conductive cutting tools, workpieces, and machine tools.

Model **BM-2G**

Preset .002" dia. tools.
Considerable reduction of set-up time for small dia. tools.



Integrated contact switch

BASE MASTER MICRO

Light pressure activation for small tools. Suitable for all cutting tools, workpieces, and machine tools.

Model **BM-2M**

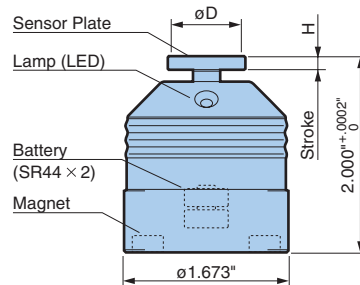

Model	Plate Diameter øD	Plate Material	Stroke H
BM-2	.709	Steel	.118
-2G	.551	Ceramic	.118
-2M	.276		.039

- BM-2 will not work with non-conductive cutting tools, workpieces, or machine tool spindles.
- For cutting tools under .040", feed slowly and touch the sensor plate carefully.
- 50mm units available upon request.

TOOL MASTER

Precision tool to define work offsets and tool length.

- Large dial is easily viewed and includes approach LED lamp and sound.
- Adjustable height.
- Magnetic base mounts vertically, horizontally, or at any angle.



For all materials, including non-conductive cutting tools, workpieces, and machine tools.

Model **TM-100**

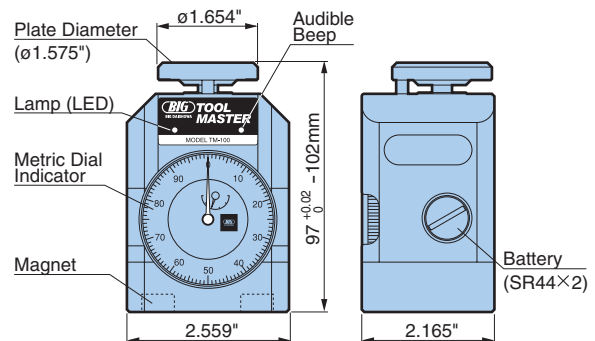

- Height: 100mm (After compressed by approx. 2mm)
- Stroke: 5mm
- Dial Graduation: 0.01mm



Touch Probe & Edge Finder

POINT MASTER Series

3-D touch sensor to quickly find measurement locations.

- Repeatability of $\pm .00008"$ with safety over-travel.
- Replaceable probes for different applications.
- Compact design.



For use with conductive cutting tools, workpieces, and machine tools.

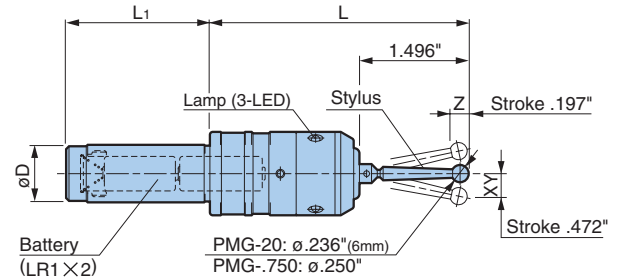

Model	ϕD h7	L	L1	Standard Stylus
PMG-20	.787	3.543	1.969	ST38-6P
-750	.750			ST38-.25P

«Additional Stylus»

Multiple Stylus available for different applications.

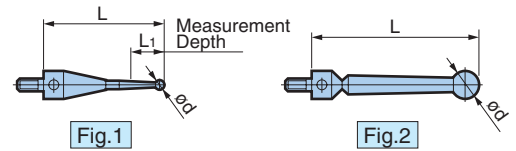

Model	Fig.	ϕd	L	L1	Material
ST28-1P	1	.040 (1mm)	1.102	.079	Carbide
-2P		.079 (2mm)		.315	
-3P		.118 (3mm)		-	
-4P		.157 (4mm)		-	
ST38-6P	2	.236 (6mm)	1.496	-	Stainless Steel
-25P		.250		-	

Application Examples	 Hole Locations	 Workpiece Offsets	 Bore Diameters
	 Boss Diameters	 Distance Between Centers	 Feature Locations



ACCU CENTER

Precision Edge Finder

- Repeatability of .00012".
 - Hard chrome plated cylindrical stylus for extended life.
- (Not for use with horizontal machine tools)

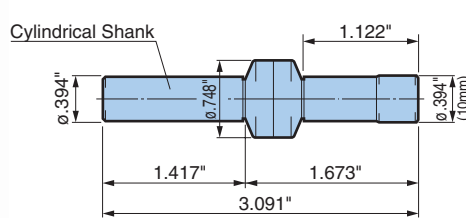
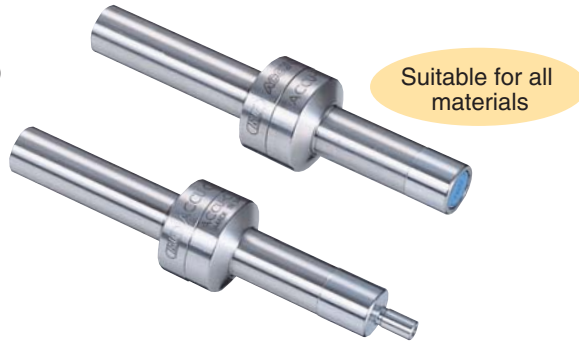

Model **ACCU-C10**

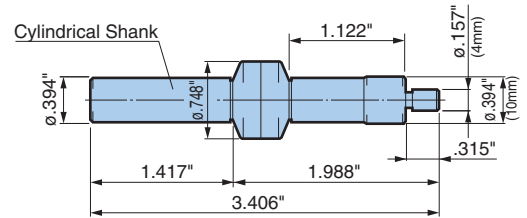

Model **ACCU-C104**

● Operation Instructions

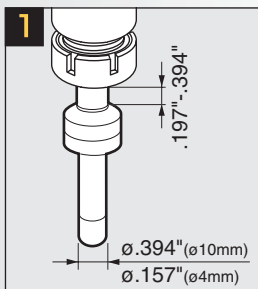

Clamp tool in a New Baby Collet Chuck.

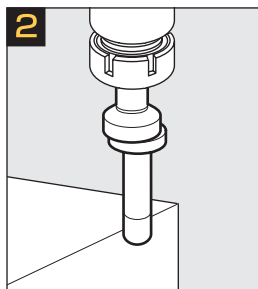

Move the stylus off center, and rotate between 400 and 600 RPM.

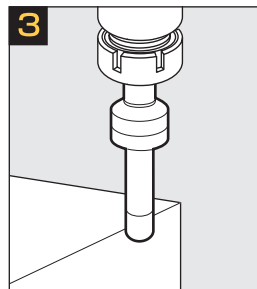

Bring the tool into contact with the workpiece and advance slowly until the stylus lines up with the body.

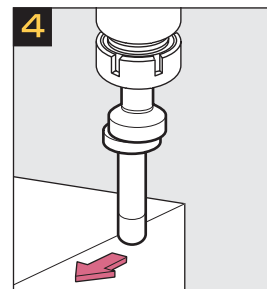

If advanced too far the stylus will again move off center. Be sure to compensate location for half the stylus diameter.