

# Mazak

## INTEGREX SERIES & INTEGREX *e* SERIES



BCV40&50  
**BIG-PLUS**

The tooling to achieve  
the highest performance  
for INTEGREX machines.

 **BIG-PLUS**  
SPINDLE SYSTEM PAT.  
DUAL CONTACT  
US Patent No. 5,352,073



INTEGREX SERIES



INTEGREX *e* SERIES

MAZAK and MAZATROL are registered  
trademarks of YAMAZAKI MAZAK CORPORATION.

**BIG DAISHOWA SEIKI CO LTD**

## Revolutionary! – The very first modular tooling system for turning applications

A modular tooling system offers better efficiency, material selection, heat treatment and optimal tool lengths. The serious damage on tool holders caused by broken inserts can now be easily and economically replaced.

### 45° Tilt style Type S

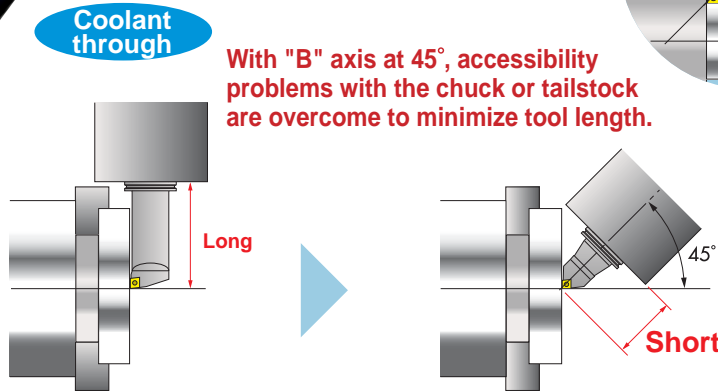
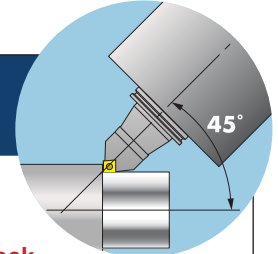

Tilting the "B" axis 45° helps to minimize the cutting forces transmitted to the machine spindle. This force reduction increases the life of the machine spindle.

15 kinds of Cartridge Type S for various applications



### Secure and rigid!! Type S Cartridge clamping system

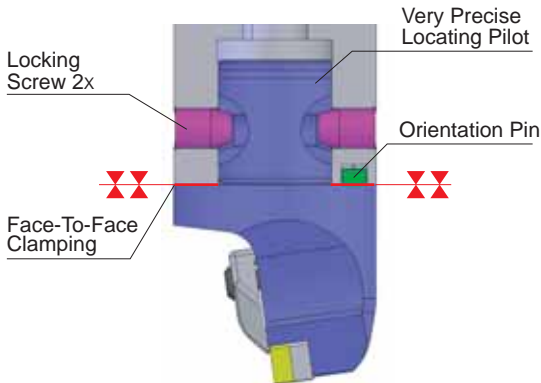

Using highly sophisticated and modern machine tools, Type S cartridges are made to very close tolerances required for turning accuracy and repeatability. The cartridge is located in the basic holder by means of a precision ground pilot and secured by 2 opposing radial screws with 15° taper. With a slight offset to locating sockets, high face-to-face clamping force of the two components is generated. To maintain precise locations and orientation, an additional locating pin is included for positive transfer of cutting torque.

All basic holders for turning applications are made with BIG-PLUS and tighter drive key tolerances required by MAZAK.

**90°** Right angle style  
**Type F**



**Basic Holder**

Coolant nozzle

**Cartridge**



Left hand

Coolant nozzle

**Center proximity type cartridge is also available, minimizing tailstock interference.**

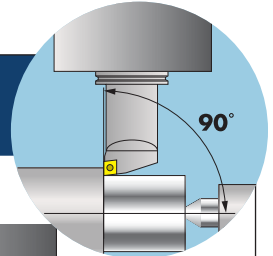
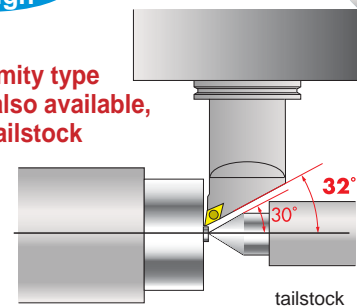

2 different basic holders are available and all can be assembled with either right or left hand version of cartridge.

12 kinds of Cartridge Type F for various applications

Right and left hand cartridges are available



**Simple and positive Type F Cartridge clamping system**

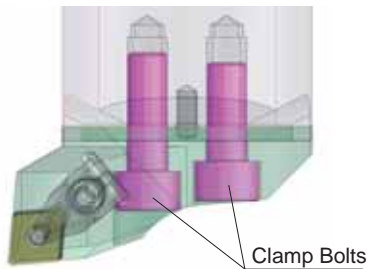

Clamp Bolts

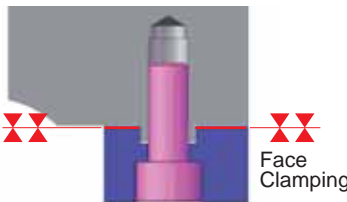

Face Clamping

Type F uses 2 clamping bolts that presses the cartridge onto the basic holder. The torque is transmitted by an interlocking drive slot.

**Precision Drive Keys**

BIG-PLUS turning tool holders are designed for INTEGREGX Machines. To maintain turning repeatability after tool change, the drive keys are precision milled after heat treat to prevent misalignment of cutting edge and centerline of workpiece.

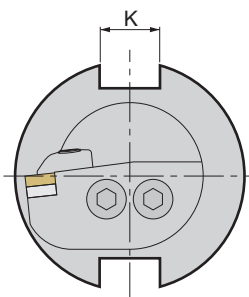

**Range of tolerance for key way**

	ASME Standard Tolerance K	BIG-PLUS Turning Tool Tolerance K
<b>CAT.40</b>	.020	.0016
<b>CAT.50</b>		.0020

# TURNING TOOLS



# MTC<sup>®</sup> TOOLING SYSTEM

**45°**

## S50 TYPE S BASIC HOLDER

BCV40Y-S50-3  
BCV50Y-S50-3.5  
-S50-4.5

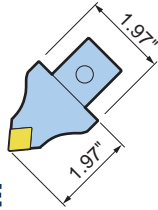

## TYPE S CARTRIDGE

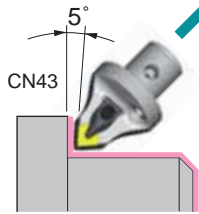

S50-DCLNN-00050-12

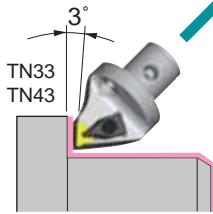

S50-DTJNR-00050-16  
-DTJNL-00050-16  
S50-DTJNR-00050-22  
-DTJNL-00050-22

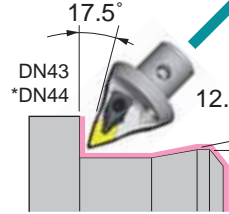

S50-DDHNN-00050-15

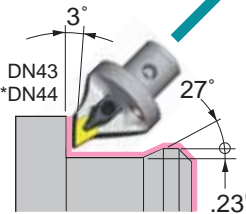

S50-DDJNR-00050-15  
-DDJNL-00050-15

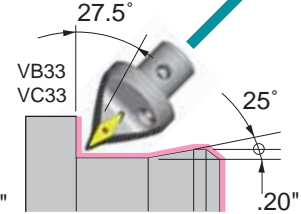

S50-SVQBN-00050-16

\*In case of DN44 insert, please replace the standard carbide shim with DNS1506(option).

**90°**

## TYPE F BASIC HOLDER

BCV40Y-F63-4.125  
BCV50Y-F63-5.125

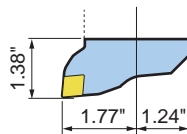
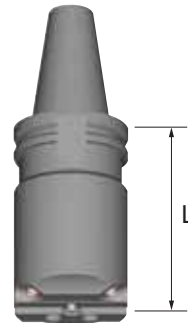

## TYPE F CARTRIDGE

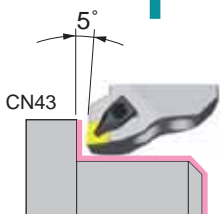

F63-DCLNR-45035-12  
-DCLNL-45035-12

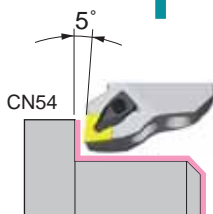

F63-DCLNR-45035-16  
-DCLNL-45035-16

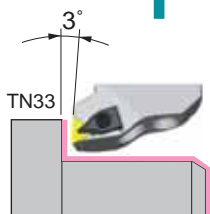

F63-DTJNR-45035-16  
-DTJNL-45035-16

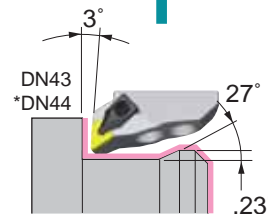

F63-DDJNR-45035-15  
-DDJNL-45035-15

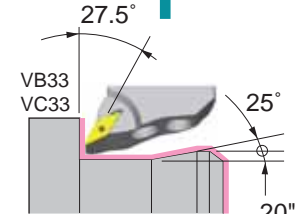

F63-SVQBR-45035-16  
-SVQBL-45035-16

\*In case of DN44 insert, please replace the standard carbide shim with DNS1506(option).

All basic holders for turning applications are made with BIG-PLUS and tighter drive key tolerances required by MAZAK.

**S63**  
**TYPE S BASIC HOLDER**

- BCV40Y-S63-2.625
- BCV50Y-S63-3.125
- S63-4.125

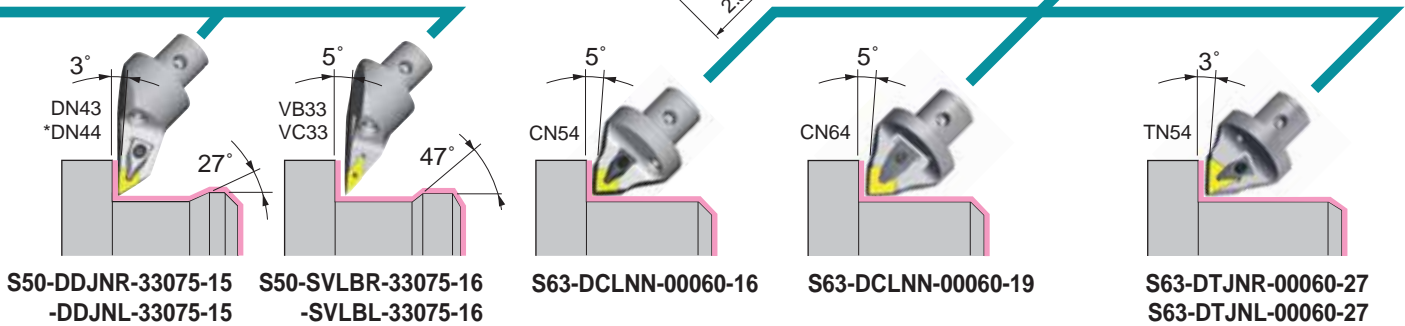
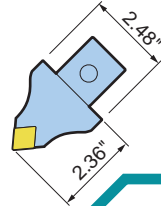
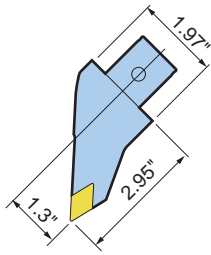

**SQUARE TOOL HOLDER**

- Size L
- BCV40Y-180-BH1.000L-5
  - 180-BH1.000R-5
  - BCV50Y-180-BH1.000L-5
  - 180-BH1.000R-5
  - 180-BH1.250L-5
  - 180-BH1.250R-5

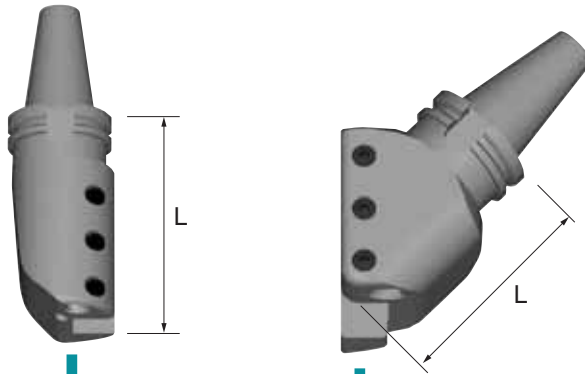

**SQUARE TOOL HOLDER**

- L
- BCV40Y-45-BH1.000L-4.75
  - 45-BH1.000R-4.75
  - BCV50Y-45-BH1.000L-5.5
  - 45-BH1.000R-5.5
  - 45-BH1.250L-5.5
  - 45-BH1.250R-5.5

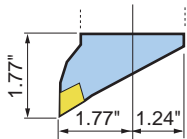

For □ shank

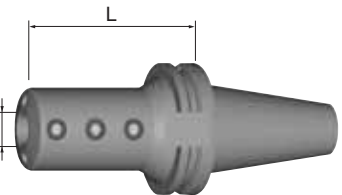

**BORING BAR HOLDER**

- |               | Ød   | L   |                | Ød   | L   |
|---------------|------|-----|----------------|------|-----|
| BCV40Y-BSL    | .625 | 3.5 | BCV50Y-BSL     | .625 | 3.5 |
| -BSL          | .750 | 3.5 | -BSL           | .750 | 3.5 |
| -BSL1.000-4   |      |     | -BSL1.000-4    |      |     |
| -BSL1.250-5   |      |     | -BSL1.250-4.5  |      |     |
| -BSL1.500-5.5 |      |     | -BSL1.500-5    |      |     |
|               |      |     | -BSL2.000-5.25 |      |     |

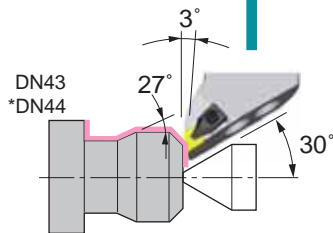

- F63-DDJNR-45055-15**
- DDJNL-45055-15**

## MEGA CHUCK SERIES

### MEGA MICRO CHUCK

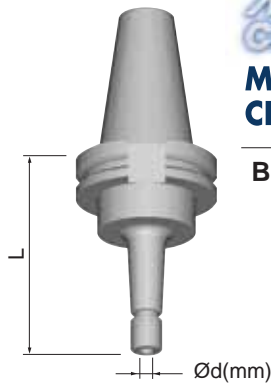

- | BCV40-MEGA3S-2.5T | -4T |
|-------------------|-----|
| -MEGA4S-2.5T      | -4T |
| -MEGA6S-2.5T      | -4T |

### MEGA MICRO COLLET

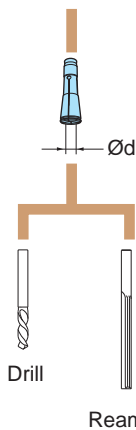

- | NBC3S-d | 4S-d | 6S-d |
|---------|------|------|
|---------|------|------|

## MEGA CHUCK SERIES

### MEGA NEW BABY CHUCK

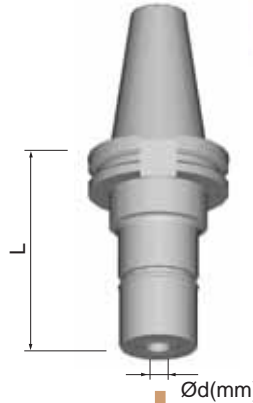

- |                               |                          |                          |                          |                          |                          |
|-------------------------------|--------------------------|--------------------------|--------------------------|--------------------------|--------------------------|
| BCV40-MEGA 6N-2.5, -4, -5, -6 | -MEGA 8N-2.5, -4, -5, -6 | -MEGA10N-2.5, -4, -5, -6 | -MEGA13N-2.5, -4, -5, -6 | -MEGA16N-2.5, -4, -5, -6 | -MEGA20N-2.5, -4, -5, -6 |
| BCV50-MEGA 6N-3.5, -5, -6     | -MEGA 8N-3.5, -5, -6     | -MEGA10N-3.5, -5, -6, -8 | -MEGA13N-3.5, -5, -6, -8 | -MEGA16N-3.5, -5, -6, -8 | -MEGA20N-3.5, -5, -6, -8 |

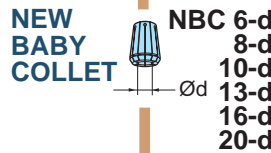

- | NEW BABY COLLET | NBC 6-d | 8-d | 10-d | 13-d | 16-d | 20-d |
|-----------------|---------|-----|------|------|------|------|
|-----------------|---------|-----|------|------|------|------|

### Coolant Nut MEGA PERFECT SEAL PAT.



US Patent No. 5,975,817

### MEGA MICRO CHUCK

## Precision Modular Tool System KAISER KAB SHANK

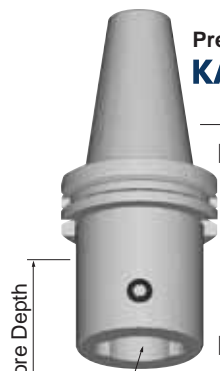

- | KAB No.     | Depth   |
|-------------|---------|
| BCV40 × KA4 | × D 3.1 |
|             | × D 6.3 |
| KA5         | × D 3.1 |
|             | × D 6.3 |
| KA6         | × D 3.9 |
|             | × D 6.3 |
| BCV50 KA4   | × D 3.9 |
|             | × D 6.3 |
|             | × D 7.8 |
| KA5         | × D 3.9 |
|             | × D 6.3 |
|             | × D 7.8 |
|             | × D10.2 |
| KA6         | × D 3.9 |
|             | × D 6.3 |
|             | × D 7.8 |
|             | × D10.2 |
|             | × D12.6 |
| KA7         | × D 6.3 |
|             | × D 8.0 |
|             | × D10.2 |



Rough Boring Finish Boring

**KAB 307A** For KAB system details Catalog

## SHELL MILL ADAPTER

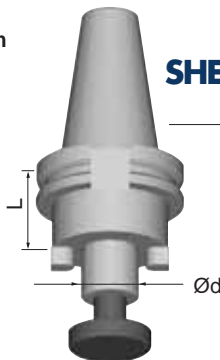

- | BCV40-SM   | .750-2       | -4 | -6 |
|------------|--------------|----|----|
| -SM1.000-2 | -4           | -6 |    |
| BCV50-SM   | .750-2       | -4 | -6 |
|            | -SM1.000-2   | -4 | -6 |
|            | -SM1.250-2   | -4 | -6 |
|            | -SM1.500-2   | -4 | -6 |
|            | -SM2.000-2   | -4 | -6 |
|            | -SM2.500-2.5 |    |    |



Shell Mill

## ENDMILL HOLDER

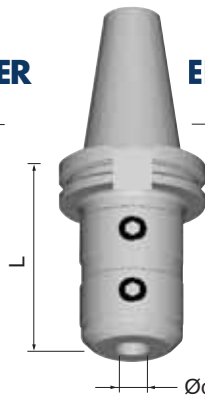

- | BCV40-EM | .500-3    | -4.5 |
|----------|-----------|------|
| -EM      | .625-3    | -4.5 |
| -EM      | .750-3    | -4.5 |
| -EM      | 1.000-3   | -4.5 |
| -EM      | 1.250-4.5 | -4.5 |
| -EM      | 1.500-5   | -4.5 |
| BCV50-EM | .500-4.5  | -4.5 |
| -EM      | .625-4.5  | -4.5 |
| -EM      | .750-4.5  | -4.5 |
| -EM      | 1.000-4.5 | -8   |
| -EM      | 1.250-4.5 | -8   |
| -EM      | 1.500-4.5 | -8   |
| -EM      | 2.000-6   | -8   |

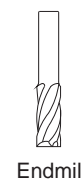

Endmill

**MEGA CHUCK SERIES**  
**MEGA E CHUCK**

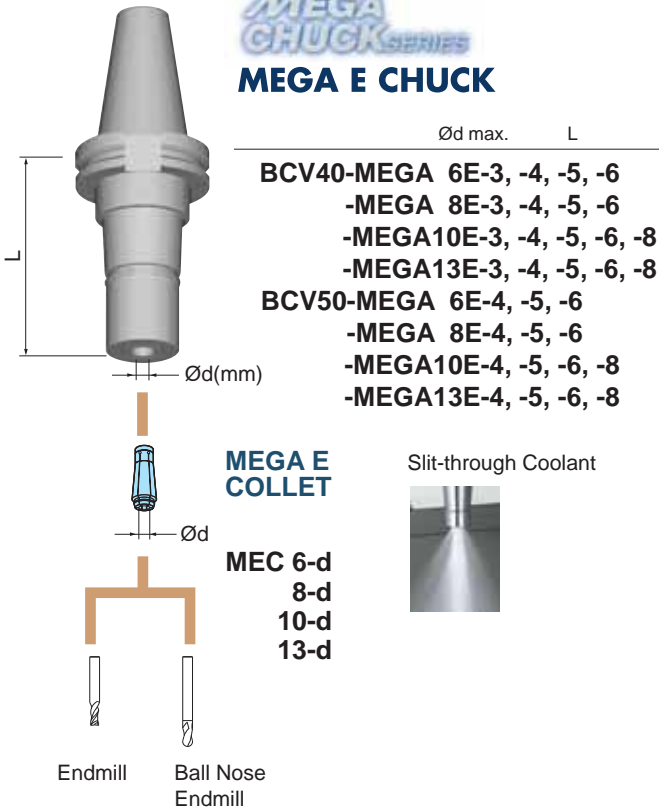

**MEGA CHUCK SERIES**  
**MEGA DOUBLE POWER CHUCK**

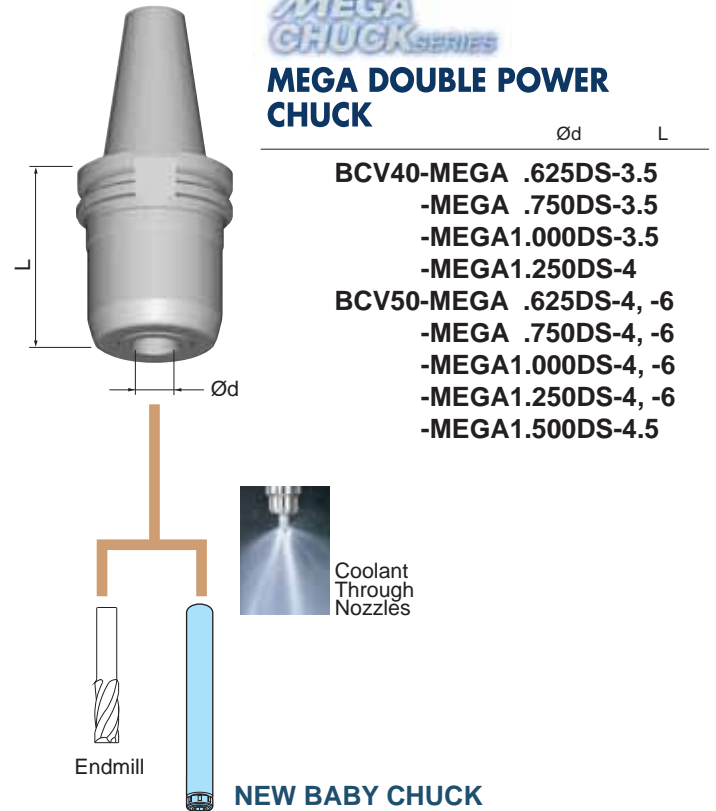

**SHRINK FIT HOLDER**

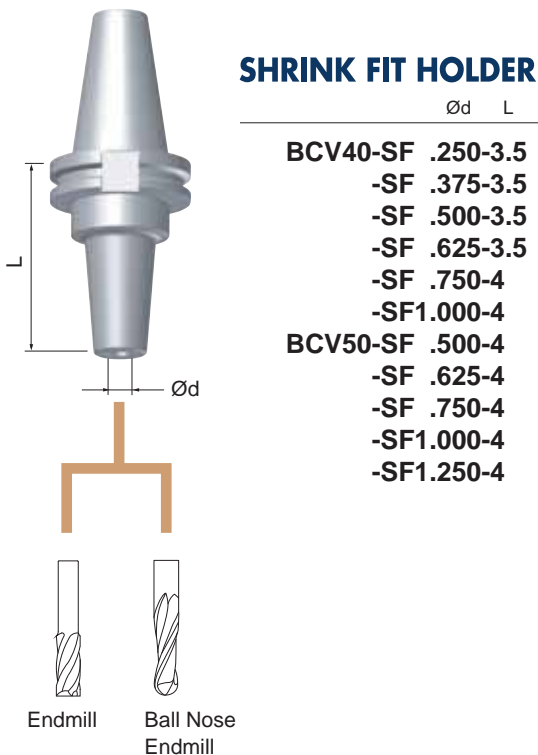

Indexable Insert Endmill  
**FULLCUT MILL FCM**

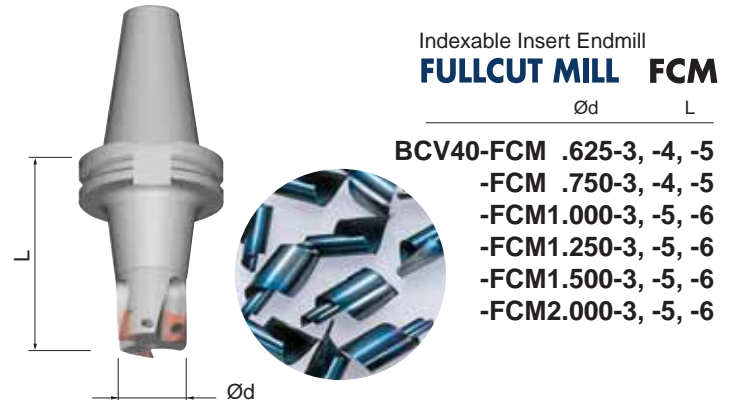

Ramping & Helical Milling Cutter  
**FULLCUT MILL FCR**

Part	$\text{Ød}$	$L$
BCV40-FCR .625-3.5, -5, -5.5		
-FCR .750-3.5, -5, -5.5		
-FCR1.000-3.5, -5, -5.5		
-FCR1.250-3.5, -5, -5.5		

# Spare parts for TURNING TOOLS

Double-clamping system of 'push and draw' assures the safe clamping of inserts.

## Clamp Piece Set

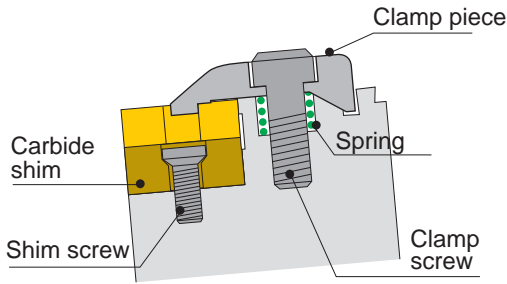

Insert Size	Set Model	Clamp Piece	Screw	Spring
TN33	SCP-1	CP1	M5 × 20	ø8 × 10
CN43	SCP-2	CP2		
DN43				
TN43	SCP-3	CP3		
CN54				
TN54	SCP-5	CP5		

- \*A set contains one clamp piece, screw and spring.
- \*A wrench is not included. Please order separately (Model: T-4).

## Carbide Shim Set

Insert	Set Model	Carbide Shim	Screw	Torx Size
CN43	SCNS1204	CNS1204	M4 × 8	T15
CN54	SCNS1606	CNS1606	M5 × 12	T20
CN64	SCNS1906	CNS1906		
TN33	STNS1604	TNS1604	M3 × 7	T10
TN43	STNS2204	TNS2204	M4 × 8	T15
TN54	STNS2706	TNS2706	M5 × 12	T20
DN43	SDNS1504	DNS1504	M4 × 8	T15
DN44	SDNS1506	DNS1506		

- \*A set contains one carbide shim and screw.
- \*A wrench is not included. Please order separately (Model: DA-T10, DA-T15, DA-T20).

## Insert Clamping Screw Set



for VB33 Insert

Model **S3508DS**

### Contents

M3.5 screws.....10 pcs.  
Wrench..... DA-T15 1 pc.

## Clamp Screw Set for Type S Basic Holder

Type	Screw Model	Screw Size	Wrench Model
S50	10.690.435	M10 × 1.0	10.690.816
S63	10.690.436	M12 × 1.0	10.690.817

## Accessory Tools

### BIG-PLUS CAT50 Adapter

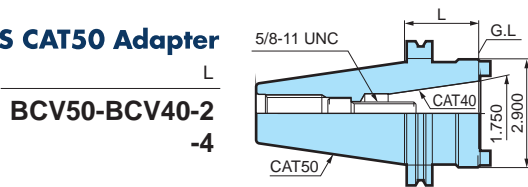

### Precision Test Bar DYNATEST

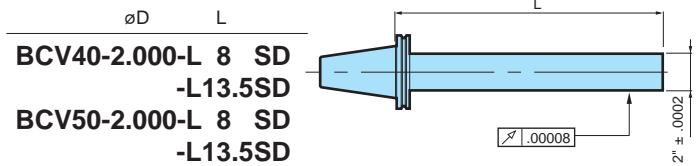

### RETENTION KNOB

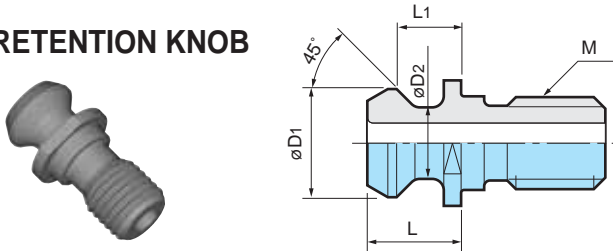

Shank	Model	øD1	øD2	L	L1	M
BCV40	PYN40C	.74	.49	.64	.44	5/8-11UNC
BCV50	PYN50C	1.14	.82	1.00	.70	1-8UNC

# BIG KAISER®

## PRECISION TOOLING INC.

641 Fargo Avenue Elk Grove Village, IL 60007  
Tel: 847.228.7660 Fax: 847.228.0881  
www.bigkaiser.com bigkaiser@bigkaiser.com

**BIG-PLUS**  
SPINDLE SYSTEM PAT.  
DUAL CONTACT

No. 48 For BIG-PLUS details  
Catalog

**BIG-PLUS**  
TOOLING SYSTEM  
EX48-4